



**INSTALLATION  
RECOMMENDATIONS  
FOR FIBERTEK  
InsuTEK1™  
FIBER GLASS  
LOOSE FILL  
INSULATION**

[www.fibertekinsulation.com](http://www.fibertekinsulation.com)

## Contents

|                                  |   |                                     |    |
|----------------------------------|---|-------------------------------------|----|
| Introduction                     | 1 | Special Attention                   | 6  |
| Installation – General           | 1 | Application                         | 6  |
| Consumer Information             | 2 | Blowing                             | 6  |
| FTC Home Insulation Rule         | 2 | Machine Pressure                    | 6  |
| Planning the Crew Operation      | 2 | Houses Without Sheathing            | 6  |
| Clothing and Equipment           | 2 | Opening Procedures For Sidewalls    | 6  |
| The Foreman’s Responsibilities   | 2 | Clapboards                          | 7  |
| Ceiling Installation Guidelines  | 3 | Novelty Siding-Horizontal           | 7  |
| Preparation                      | 3 | Shiplap                             | 8  |
| Special Attention                | 3 | Tongue-and-Groove                   | 8  |
| Installation                     | 3 | Vertical Siding Over Sheathing      | 9  |
| Application                      | 4 | Wood Siding Shingles                | 9  |
| Unfloored Attics                 | 4 | Brick Veneer                        | 10 |
| Floored Attics                   | 4 | Alternate Suggestions For Sidewalls | 10 |
| Attic Knee Walls and Slopes      | 5 | Residing                            | 10 |
| Attic Stairways                  | 5 | Interior Application                | 10 |
| Sidewall Installation Guidelines | 5 | Material Specifications             | 11 |
| Preparation                      | 5 |                                     |    |



925 South 4400 West  
Salt Lake City, Utah 84104  
(877) 862 4448 (801) 972 3244  
[info@fibertekinsulation.com](mailto:info@fibertekinsulation.com)  
[www.fibertekinsulation.com](http://www.fibertekinsulation.com)

## HORIZONTAL OPEN BLOW

| R-VALUE@75°F                       | Bags per 1000 sq.ft. No Joists                                 | Net Coverage sq.ft. per bag                      | Minimum Weight lbs / sq.ft.                                    | Initial Installed Thickness (in.)             | Minimum Settled Thickness(in.)                |
|------------------------------------|--|--|--|---|---|
| To obtain a thermal resistance of: | The number of bags/1000sf of net area should not be less than: | Contents of this bag should not cover more than: | The weight/sf of installed insulation should not be less than: | Installed insulation should not be less than: | Installed insulation should not be less than: |
| 11                                 | 6.3  | 159.0  | 0.17   | 4.82  | 4.82  |
| 13                                 | 7.5  | 133.1  | 0.20   | 5.52  | 5.52  |
| 19                                 | 11.2   | 89.3   | 0.30   | 7.62  | 7.62  |
| 22                                 | 13.0   | 76.7   | 0.35   | 8.67  | 8.67  |
| 26                                 | 15.5   | 64.5   | 0.42   | 10.10   | 10.10   |
| 30                                 | 18.0   | 55.7   | 0.48   | 11.50   | 11.50   |
| 38                                 | 22.9   | 43.7   | 0.62   | 14.30   | 14.30   |
| 44                                 | 26.6   | 37.6   | 0.72   | 16.40   | 16.40   |
| 49                                 | 29.7   | 33.7   | 0.80   | 18.20   | 18.20   |
| 60                                 | 36.4   | 27.4   | 0.98   | 22.00   | 22.00   |

Initial installed thickness determined according to ASTM C1374 using a Unisul Volumatic machine. Machine settings are not adjustable.

BAG WEIGHT - NOMINAL 27LBS

## SIDEWALL / UNDERFLOOR - 1.6 lbs/cu.ft. design density

| R-VALUE@75°F                       | Bags per 1000 sq.ft. No Joists                                 | Net Coverage sq.ft. per bag                      | Minimum Weight lbs / sq.ft.                                    | Initial Installed Thickness (in.)             | Minimum Settled Thickness(in.)                |
|------------------------------------|--|--|--|---|---|
| To obtain a thermal resistance of: | The number of bags/1000sf of net area should not be less than: | Contents of this bag should not cover more than: | The weight/sf of installed insulation should not be less than: | Installed insulation should not be less than: | Installed insulation should not be less than: |
| 15                                 | 17.3   | 57.9   | 0.467  | 3.50  | 3.50  |
| 23                                 | 27.2   | 36.8   | 0.733  | 5.50  | 5.50  |
| 30                                 | 37.0   | 27.0   | 1.000  | 7.50  | 7.50  |

## Introduction

InsulTEK1™ loose fill insulation is a viable alternative to batts and rolls in difficult access areas such as truss attics or closed wall cavities (retrofit). It is also widely used in conventional attics as a matter of builder or homeowner preference.

The installation process for InsulTEK1™ loose fill insulation is more complex than for batts or rolls because a blowing machine is required for installing loose fill. This dictates that workers be carefully trained to install loose fill products in strict accordance with coverage charts. (See above)

## Installation – General

InsulTEK1™ blown fiber glass insulation generally can be installed in all ceiling and sidewall areas as well as in other exposed areas such as overhanging floors. Loose fill is properly specified by R-value, not inches of thickness. The “R” stands for resistance to the flow

of heat and is a measure of how effective the installed insulation will be.

The higher the R-value the greater the insulating power. Ask your seller for the fact sheet on R-values. It is important that the R-value being considered is the value for the total amount of insulation used.

In order to achieve the specified R-value, InsulTEK1™ loose fill must be installed so that at least the minimum thickness and weight per square foot are achieved. The only practical way to do that is to be sure to install at least the minimum number of bags per 1000 square feet as specified on the label coverage chart. (See above).

The number of bags per 1,000 sq. ft. is based upon net area, which is the total area minus the area covered by framing members and other obstructions, while job size is usually figured as total (or gross) area.

Because the net area will always be smaller than the

gross, the number of bags per 1,000 sq. ft. of gross area may be reduced slightly, generally 3 to 8 percent, from the number on the label.

However, the bag label makes no allowance for the additional material that might be needed where blowing is difficult, such as under flooring or at obstructions where the insulation may pack.

## Consumer Information

### FTC Home Insulation Rule

The United States Federal Trade Commission's Labeling and Advertising of Home Insulation Rule requires installers to provide each customer (builder or consumer) with a signed and dated contract or receipt for the InsulTEK1™ insulation installed.

The receipt for InsulTEK1™ loose-fill must show the type of insulation, coverage area, thickness, R-value and number of bags installed. Installers must have this information and show it to customers before they agree to buy the insulation.

A new-home seller must put the following information in every sales contract: the type, thickness, and R-value of the insulation that will be installed in each part of the house.

## Planning the Crew Operation

A well-trained crew is essential, both to ensure that the insulation is installed correctly and to meet time and cost objectives.

Every crew should have a lead person responsible for the job. The size of a crew will vary, depending upon the type of blowing equipment and the particular job. A minimum of two people is recommended, even on ceiling jobs done with automatic machines. Where both ceilings and sidewalls are to be insulated, it may be advisable to use as many as four people, one of whom must be a competent carpenter. A foreman may be provided on jobs where a single crew consists of four or more men or where more than one crew is working on the same job.

### Clothing and Equipment

#### Clothing

When installing InsulTEK1™ loose fill insulations you must:

- Wear a long sleeved shirt loose at the neck and wrists, long pants, gloves and cap.
- Wear eye protection (safety goggles, safety glasses or a face shield or a combination of these, as appropriate).
- Use a NIOSH/MSHA approved disposable dust respirator, such as a 3M model #8710 or #9900 or equivalent. An appropriate training and fitting program must be incorporated into a respiratory protection program.

#### Equipment

In addition to the usual tools needed to operate equipment and prepare the installation site, carry an extension light with long cord, extra bulbs, a step ladder and a flashlight for use in dark attics and closed-in areas.

### The Foreman's Responsibilities

A foreman should be thoroughly familiar with all phases of the work for all jobs. His responsibilities are:

- To locate all areas which require insulation.
- To locate any work areas that cannot be insulated or should be carefully avoided (i.e. recessed lighting fixtures, stud cavities containing heating, ventilation and air conditioning ducts).
- To see that the InsulTEK1™ insulation is properly applied to meet local codes and ordinances.
- To make sure that all openings and other changes to the building are returned as closely as possible to their original appearance.
- To assure that he and his crew perform their work with the least possible annoyance to the home owner.
- To make a thorough survey of the job before starting any work and note any pre-existing damage to the property. To notify owner of damaged areas prior to installing InsulTEK1™ insulation in those areas.
- To request permission to enter the house and check the condition of interior walls and to suggest removal of dishes on shelves, mirrors, and pictures which might be dislodged during the application process.
- To make sure all openings from the attic to the living

space, or from sidewalls into living space, are covered and sealed.

- To see that the other members of the crew conduct themselves in a workmanlike manner while the job is in progress. The conversation of the crew members should not disturb the occupants of the house. Under no circumstances should the crew argue about how a job should be performed.

- To obtain changes in the work orders in writing and have them signed by both the home owner and foreman.

- To supervise the careful cleaning of buildings and grounds at job completion. It is generally an excellent idea for the foreman to offer the home owner the opportunity of seeing those parts of the completed insulation job which are accessible.

- To have the home owner or builder sign the contract or receipt which states that the job has been satisfactorily completed.

- Frequently the foreman will be given leads to other prospective insulation purchasers. Although it is not his specific responsibility, a good foreman never misses the opportunity to get his company's name to an interested prospect or to turn the prospect's name over to his boss.

## Ceiling Installation Guidelines

### Preparation

#### Scheduling

Since the attic area is generally the most accessible part of the house, most crews will start there. For practical scheduling, the attic should always be saved for inclement weather.

#### Lighting

Be sure there is sufficient light by which to work. Every crew should carry a long extension cord with extra bulbs to use whenever the attic is not sufficiently lighted. The hoseman should also have a flashlight.

#### Clear Attic Area

Before starting to insulate in the attic, anything which might interfere with the movement of the hoseman or the proper application of the insulation should be removed or placed in an area where it will give the least amount of trouble.

Items stored in the attic should be protected as much

as possible. Clothes and other items which could be affected by the insulation must be removed from the attic.

### Special Attention

- Be sure that eave vents are not blocked. Ways to shield these openings are shown in Figure 1.

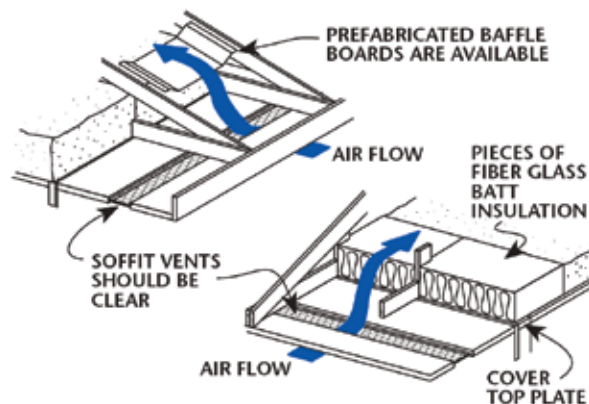

Figure 1

- Small openings should be hand packed with InsulTEK1™ fiber glass insulation.

- Cavities, drops, and scuttles should be covered with InsulTEK1™ insulation or their sides and bottoms should be insulated. Drops can be floored with gypsum board or other suitable material so that insulation can be properly applied.

- Recessed lighting fixtures and fan motors protruding into the ceiling must not be covered with insulation and insulation should be held three inches away from their sides, in accordance with recommendations of the National Electric Code. The purpose is to prevent overheating of fixtures. Prior to installation, these areas can be isolated or blocked by using pieces of fiber glass batts (3 inches away) or prefabricated barriers. (This warning does not apply to Type IC fixtures or flu rescent fixtures with thermally protected ballasts.)

- It may be necessary to install BIGBATT™ insulation over suspended acoustical ceilings and other similar "special" areas.

### Installation

When installing InsulTEK1™ loose fill insulation it is recommended:

- To achieve the desired R-value, you must install at least the number of bags required by the label to at least the minimum thickness required by the bag label. To ensure the minimum insulation thickness, the International Energy Conservation Code (IECC) requires that rulers be attached in each 300 sq. ft. area of the attic to use as gauges during installation.

- Make sure the machine is set in accordance with instructions on the InsulTEK1™ bag. (Settings may vary depending on the machine condition, climatic factors and application techniques.)

The machine settings were developed by manufacturers using machines in good working order and application techniques considered to be acceptable in normal field operation. It may be necessary to make some adjustments to these initial settings to fine tune the performance of the equipment.

- When blowing, keep the hose level, and install with a minimum of hand deflection. Always blow with, not across, the joists.

- Section the attic into quarters and make sure one-quarter of the specified number of bags is used in each section to achieve the desired R-value.

## Application

### Unfloored Attics

- Keep the hose parallel to the floor, with the InsulTEK1™ insulation falling 10 to 12 feet in front. Where possible, back away from work to prevent packing.

- Where work space is tight, prevent the InsulTEK1™ insulation from packing by allowing it to blow off your hand.

- Blow three or four joist spaces from one position by moving the hose to the right or the left. Always blow in the direction of joists, not across them.

- Keep the hose close to the floor where insulation must go underneath obstructions such as cross-bracing and wiring. InsulTEK1™ must be blown on both sides of this kind of obstruction.

- Where an obstruction may cause a low spot to occur, move around, check this spot and, if necessary, fill in the low area.

- Be sure that InsulTEK1™ is installed on both sides of obstructions such as solid crossbracing and masonry chimneys.

- If a batt or baffle is not used to block off the ends of joists, be sure that InsulTEK1™ is applied all the way to the outer edge of the plate.

- When roof construction does not allow full depth to the ends of the joists, bounce the insulation off the underside of the roof to increase density in that area. Care should be taken not to block the eave vents. (See Figure 1.)

- To prevent overheating of recessed light fixtures, do not insulate on top of or within three inches of such devices. To be in accordance with the current National Electric Code, provide a way of holding the insulation away by making a shield of noncombustible material. For local requirements, contact your local building department. (This warning does not apply to Type IC fixtures or fluorescent fixtures with thermally protected ballasts.)

- Use only BIGBATT™ unfaced fiber glass insulation between wood framing™ and masonry chimneys. Do not place insulation in air spaces surrounding metal chimneys or fireplaces.

- Clearances around fossil fuel appliances should meet the requirements of the National Fire Protection Association (NFPA) or appliance manufacturer's recommendations.

- Water pipes run in the attic area must be given protection since the attic temperature during cold weather will now be very close to that of the outdoors. The severity of the winters and the location of the pipes will determine what is required to prevent freezing.

- After the attic is blown, even out any high or low spots.

- Do not remove the hose from the attic until the foreman has inspected and determined that no areas have been accidentally missed and that the correct number of bags has been installed.

- Install a piece of BIGBATT™ insulation on top of areas where loose fill has not been applied, such as access panels, stair wells, and fan covers. The completed job should provide a continuous layer of insulation over the entire ceiling area.

### Floored Attics

- Many attic areas contain some floored areas, which

present no real problem. It is not advisable to attempt to blow more than 4 to 6 feet under flooring, so floor boards should be removed approximately every 8 to 12 feet.

- Some flooring is difficult to remove because of its nailing pattern. When that is the case, take care during removal to prevent damage to the ceiling surface below.
- Since it is difficult to see bracing underneath the flooring, take particular care to ensure that the flow of insulation under the floor is not being blocked. When there is a large amount of bracing or wiring under the floor, it may be necessary to take off several boards in a small area.
- Insert the hose approximately 4 to 6 feet under the floor and gradually pull it out as the space fills with insulation. Twist and turn the hose as it is removed in order to ensure complete coverage of the area under the floor.

#### Attic Knee Walls and Slopes

- Some houses contain finished attics. This type of construction can have both knee walls and flat and sloped ceilings. Although it is possible to use retainers and blow knee walls, it is easier to use BIGBATT™ insulation (See Figure 2.)

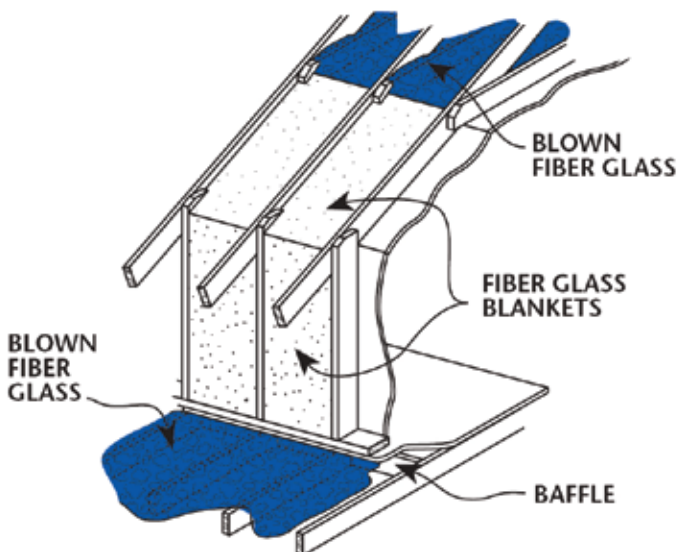

Figure 2

#### Attic Stairways, Scuttles and Pull-Down Stairs

- Many older homes have attic stairways. A ceiling insulation job is not complete until the stairway is insulated, including the soffit area, the walls, and the door.
- Many times the soffit area can be filled with InsulTEK1™ by either removing the treads or drilling holes and filling with InsulTEK1™. Close holes by means of plugs. Plugs can be finished and restrained or painted as necessary.
- Stairway walls can be insulated in the same manner as any other wall. Finish the openings as required to match the existing stairway finish.
- An alternate to insulating the entire stairway assembly is to install a trap door, operated by a counterbalance, over the top of the stairway and insulate it with BIGBATT™ insulation.
- Scuttles and pull-down stairs should be insulated. Insulation can be attached directly to the scuttle hatch. Insulated boxes are available for insulated pull-down stairs.

## Sidewall Installation

### Guidelines

#### Preparation

A crew that has not previously blown sidewalls of existing houses should study general framing principles in houses under construction. By studying a wall section before the interior finish is put up, a person has a much better idea of how such things as firestops, junction boxes, electrical cables and bracing will affect the job.

Regardless of the outside finish, all sidewalls are insulated in a similar manner. Some of the outside finish is removed and openings are made in the sheathing so that fiber glass can be blown into the empty stud spaces. (See Figure 3.)

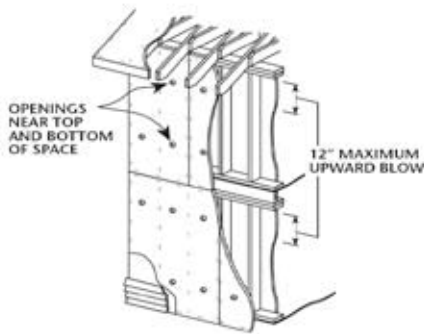

**Figure 3**

## Special Attention

- The “double blow” method, with two openings, is commonly used for sidewalls. Some stud sections may require three or more openings because of construction features.

Openings should be made into the stud area for each 4-to-5 foot height. This is essential to ensure that the stud space is completely full.

Never try to blow more than 4 feet down or 12 inches up. Blowing through a single opening in an 8-foot wall could leave some of the stud space with no insulation.

- Many homes have eaves which are below the level of the wall plate. Frequently, access to stud spaces can be gained by removing the eave panels.

- Plumb bob all stud cavities to determine the depth that can be filled through that opening. A plumb bob should be of sufficient size to readily reveal obstructions which could stop the flow of insulation.

Areas above and below windows and below firestops and bracing must be opened to determine exact location of obstructions and assure that the cavity is completely filled.

- When removing the nozzle be sure to fill the space which it had occupied.

- Some installers use the insert tube method, which consists of cutting one hole either at mid-height or near the top of each stud cavity. Insulation is blown into each cavity through a tube inserted to the bottom of the cavity and slowly withdrawn as the cavity is filled. The procedure is then repeated with the tube inserted in an upward direction.

## Application

After the sidewall has been properly opened, InsulTEK1™ fiber glass is blown into all cavities. A swivel

sidewall nozzle should be used in blowing sidewalls, unless holes are large enough for the applicator to control the direction of flow.

## Blowing

Different applicators have different methods of filling sidewalls, but it is generally recommended that the lower holes be filled first to insure that the lower parts of stud cavities are filled.

## Machine Pressure

The amount of pressure at which a machine should operate will vary with the job.

The blowing machine should be equipped with a properly operating pop-off valve so that when the wall section is filled, pressure will bleed off at the machine rather than into the sidewall section, eliminating the danger of blowing out the inside wall surface.

Considerably less pressure should be used on a sidewall in which the inner surface is a drywall construction than on one in which the inner surface is lath and plaster. As the insulation is being blown into the sidewall, continually move the blowing nozzle from one side to the other so that the entire stud area will be filled.

The experienced operator will be able to judge the approximate length of time it will take to fill any opening. If an opening is filled too quickly, it probably indicates that the insulation has hung up on some type of obstruction. When this occurs, it may be possible, by swiveling the nozzle from side to side, to break the jam. A plumb bob dropped from above may also work. In some cases it will be necessary to make another opening below the stoppage. The applicator should remember that any sidewall section which is not properly insulated will be very evident as a cold spot on the inside wall.

## Houses Without Sheathing

On some houses, siding is nailed directly to the faces of the studs without any sheathing. With this type of construction, removal of the siding will result in an opening into the stud area which is too large for proper use of the sidewall nozzle. In such cases, use a length of lumber approximately 24 inches long and the appropriate width as a substitute for sheathing, drilling a hole in it for inserting the sidewall nozzle.

## Opening Procedures For Sidewalls

The information contained in the following paragraphs covers the procedure for the removal and replacement of different types of sidewall materials. There



can be many variations of the procedures shown, and any method which gives sufficient access to the side-wall area can be used.

The opening and closing of sidewalls is the only visible evidence of a re-insulation job, and the care and attention given to it is a direct indication of the contractor's thoroughness and workmanship.

Since the removal and repair of the outside finishes on an existing home largely involve the principles of good carpentry, it is strongly recommended that one of the crew be a proficient carpenter. If one of the crew is not a carpenter, it is suggested that a carpenter be hired to work with and train your people on the first few sidewall jobs. For brick or stone sidewalls it is recommended that an experienced mason be used until your crew is familiar with the procedure for entering these walls.

## Clapboards

### Removal and Preparation for Blowing

- Tools usually required are back saws, a widefaced chisel, a curved siding chisel, a claw hammer, a nail set and a nail saw.

- The clapboard to be removed is shown as No. 2 in the drawing, Figure 4.

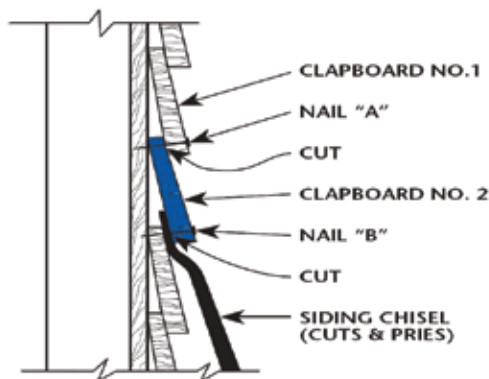

Figure 4

Removal and preparatory steps are as follows:

- Free the vertical end joints of the clapboard on either side or cut new vertical joints with a back saw if only a portion of the board has to be removed.

- Using a chisel, cut nails (A) through clapboard No. 1 that holds the upper edge of the clapboard (No. 2) to be removed.

- Cut the nails (B) in the lower edge of the clapboard (No. 2) to be removed. (Nails need not be cut if they can be removed when the clapboard is pried from the wall.)

- Pry clapboard (No. 2) from the wall and pull down to remove.

- After the clapboard has been removed, the building paper, usually found between clapboards and sheathing, should not be removed or damaged any more than necessary. Start by cutting the paper along the horizontal edge about 1 inch above the clapboard still in place.

- Make a vertical cut in the paper near each end of the exposed portion, then fold it up and tack to the clapboard above, allowing free access to the sheathing.

- Drill the holes.

### Replacement After Blowing

After the wall section has been blown, push the building paper back into place. Make sure all holes are covered with building paper and replace the clapboard in a workmanlike manner, filling any nail holes or splits with putty and touch up. If possible, leave a very slight opening between the replaced clapboard and the ones already on the house in order to permit breathing of the wall.

*Note: The Department of Energy, under the Residential Conservation Service Program Installation Practice, states: "Close all entry holes in a workmanlike manner using materials compatible with the original materials. Do not close entry holes in sheathing which is covered by an exterior brick veneer or siding."*

### Alternates in Removing Clapboards

A nail saw may be used instead of a chisel for cutting nails. Otherwise the procedure is the same. In isolated cases it may be necessary to set the nails through both clapboards and into the sheathing, using a nail set. This method is not recommended unless absolutely necessary because the bottom of the clapboard may be split and the nail set creates large holes in the clapboard requiring a large amount of puttying that usually shows up badly in the completed job.

### Novelty Siding-Horizontal

Novelty siding (regardless of its exterior appearance) usually has one common characteristic the boards are joined together by some form of shiplap or tongue-and-groove joint. In this type of work, there

is no opportunity to pry the boards loose. Therefore, the following steps are practically the only methods by which the work should be handled.

Tools required are a claw hammer, a wood chisel, a broad curved-blade knife with a striking plate on the back side of the blade, and a nail set.

The procedures are outlined below.

### ***Shiplap***

#### **Removal and Preparation for Blowing**

- Set the nails directly through the siding.
- After setting the nails, the procedure is practically the same as that for clapboards. The chisel is inserted under the lower edge of the board to be removed and pried outward (Figure 5). As the illustration of the shiplap joint shows in Figure 5 there is nothing to prevent the removal of the board.
- Preparations for blowing (treatment of sheathing, etc., and drilling) are the same as for clapboards.

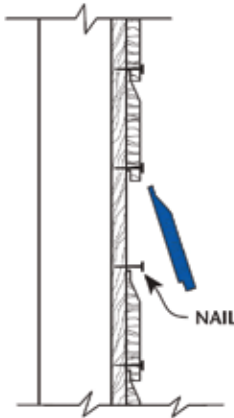

**Figure 5**

#### **Replacement After Blowing**

The procedure is the same as that described for clapboards.

### ***Tongue-and-Groove***

With tongue-and-groove work a slightly different procedure is necessary as the boards cannot be pried out without breaking either the tongue or one of the edges. Two methods are in use at present. Both can be recommended, although where the boards are very tightly fitted Method No. 1 is likely to split off the

outer edge of the board.

### ***Method No. 1***

#### **Removal and Preparation for Blowing**

- Set all nails directly through to the sheathing.
- At the lower edge of the board to be removed, insert an electrician's chisel and pry out and down at the point "A" as shown in Figure 6. This will usually cause the board to split off at the rear along the line "B", leaving the tongue of the board below intact.
- By proper manipulation, board No.1 will come away from the groove in the board above and can be removed.
- Preparations for blowing (treatment of sheathing, etc., and hole cutting) are the same as for clapboards.

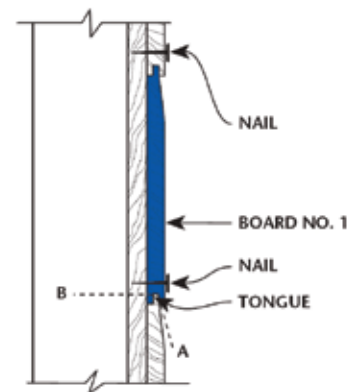

**Figure 6**

#### **Replacement After Blowing**

Set the edge of the tongue into the groove of the upper board and tap the board along the edges until the tongue is started in the groove along the entire length. When the the tongue has entered the groove far enough so that bottom edges are level, the bottom edge can be knocked straight in and the board is now ready for face nailing. Finishing nails are used in the same manner as for clapboards.

### ***Method No. 2***

#### **Removal and Preparation for Blowing**

Where the boards are set in tightly and there is dan-

ger that the board cannot be freed at the top tongue, the following alternate method is suggested:

- Set the nails through the board.
- Use a broad-bladed knife about 12" long, with a slight curvature to the blade face and a welded striking plate on the blade. The knife blade is inserted in the groove at both top and bottom of the board to be removed and driven in, in order to cut off the tongue. After the tongues are completely cut away from the board, top and bottom, the board can be easily removed. If the board is toe-nailed at the top edge through the groove instead of straight-nailed, the procedure is the same except that slightly more prying is required.
- Preparations for blowing (treatment of sheathing, etc., and hole cutting) are the same as for clapboards.

#### Replacement After Blowing

Cover the sheathing, behind the top and bottom edges of the board, with mastic the full length of the board. Finishing nails are used in the same manner as for clapboards.

#### Vertical Siding Over Horizontal Sheathing

The method of removing and replacing vertical siding over horizontal sheathing is the same as for horizontal siding. Boring and blowing behind the sheathing are carried out as set forth in "Sidewall Insulation Guidelines."

#### Wood Siding Shingles

The following methods apply only to the handling of wood shingles on sidewalls.

##### Method No. 1

#### Removal and Preparation for Blowing

Where this method is to be considered, the owner should be informed of the procedure and permission secured before beginning. Otherwise, the shingles should be pulled as in Method No. 2.

- Using a sharp utility knife (wallboard knife or chisel) cut upward at a 45° angle as far as possible under the butt end of the shingle course above. Make a series of shallow cuts through the shingle to be removed.
- Cut the paint seal at the sides of the shingle and remove the shingle.

- Drill through the lower course of shingles to the stud cavity.
- Blowing: See "Sidewall Insulation Guidelines."

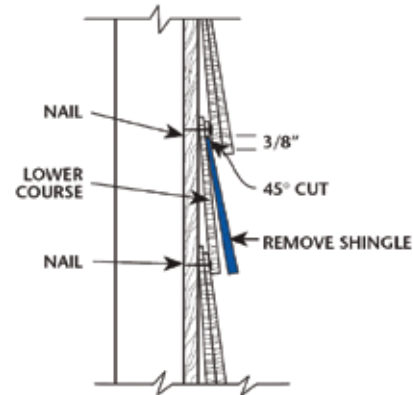

Figure 7

#### Replacement After Blowing

- Tack pieces of asphalt paper over all holes.
- Daub the back of the shingle to be replaced along the cut edge with mastic and drive it solidly up against the section of the shingle still in place.
- Face-nail the shingle with 4d or 6d galvanized finishing nails or light gauge aluminum nails. Use a minimum number of nails to fasten the thin upper edge of the shingle to reduce the possibility of splitting.
- Touch up edges and other necessary spots with paint.

##### Method No. 2

#### Removal and Preparation for Blowing

If the owner should object to cutting the shingles as in Method No. 1, the following procedure, consisting of pulling shingles, can be used. Essential tools are shingle or slatter rippers and nail saw.

- With knife, free edges of shingle by cutting the paint seal.
- Pry up the course above the shingle to be removed. Then pry up the shingle to be removed.
- Running the ripper or saw above the shingles to be removed, cut the nails holding the course above to

this shingle.

- Inserting the ripper or saw under the shingle to be removed, cut or pull the nails holding this shingle.
- Holding the shingle by the butt, work the shingle loose and pull out.
- Cut holes through the lower course of shingle and through the sheathing.

#### **Replacement After Blowing**

- Steps preliminary to the replacement of the shingle are the same as for Method No. 1.
- Replace the shingle removed and drive it upwards until the edge of the butt lines up with the rest of the course. Use a block of wood against the butt end in order to save the shingle edge.
- Face-nail the shingle with 4d or 6d galvanized aluminum nails. Use a minimum number of nails to fasten the thin upper edge of the shingle to reduce the possibility of splitting.
- Touch up edges and other necessary spots with paint.

#### **Brick Veneer**

Brick veneer construction consists of a 4-inch brick wall attached to sheathing which is nailed to studs. Where access to the stud cavity is not possible by removal of trim, it will be necessary to remove individual bricks to achieve the recommended openings at the top and bottom of the stud cavities.

It is of utmost importance that the number of openings be minimized. Thus, it is desirable to remove bricks that straddle the studding, as this permits access to two stud cavities through one opening.

Where it is necessary to remove two or three bricks, the combination may be two bricks beside each other or two beside each other and one above or below. When blowing only one cavity, the removal of a single brick per opening will usually suffice.

When installing InsulTEK1™ loose fill insulation into brick veneer walls, a 2" nozzle rather than a 2-1/2" will make the job easier. When doing brick walls, strongly

consider the use of an experienced mason if your crews are not experienced in this type of construction.

#### **Brick Removal**

There are two methods of removing brick. Whenever possible the first method should be used.

- Removal of the brick itself by removing the mortar around it.
- Actually breaking the brick out in pieces. To remove the brick in its entirety, it is necessary to remove the mortar around it. This can be done by drilling four holes (one at each corner of the brick) and chiseling out the mortar between them. Power chisels make this a relatively easy operation on some jobs. Another method of removing the mortar joint is by the use of a power saw with a special cement-cutting blade.

#### **Replacement of Brick**

After the panels are filled, the brick should be carefully replaced, matching the old mortar as closely as possible. Mortar may be given an aged appearance with the aid of a blow torch or may be colored to match or blend.

### **Alternate Suggestions For Opening Sidewalls**

#### **Residing**

If the exterior of the house is to be resided, openings may be made as necessary through the existing (old) exterior finish.

#### **Interior Application**

If rooms are to be redecorated by the homeowner, it is easier, less expensive and therefore often desirable to insulate sidewalls from the interior. Openings can be concealed at the time of redecoration. With drywall construction, save the plugs for reuse when patching the wall. Interior application should be investigated, particularly where the exterior finish is stone, brick, or stucco.

## Thermal Recommendations

When building a new home, consumers and builders alike should make sure their homes are insulated to save energy and to provide more comfortable living. The International Code Council (ICC) publishes the International Energy Conservation Code (IECC) which recommends specific thermal performance requirements.

The IECC can be ordered from any of the following model code organizations:

### **Building Officials and Code Administrators**

#### **International, Inc.**

4051 West Flossmoor Road  
Country Club Hills, Illinois 60478-5795  
(708) 799-2300

### **International Conference of Building Officials**

5360 Workman Mill Road  
Whittier, California 90601-2298  
(562) 699-0541

### **Southern Building Code Congress International, Inc.**

900 Montclair Road  
Birmingham, Alabama 35213-1206  
(205) 591-1853

For information regarding other fuel sources, visit the DOE website at:

[http://www.eren.doe.gov/consumerinfo/energy\\_savers/r-value\\_map.html](http://www.eren.doe.gov/consumerinfo/energy_savers/r-value_map.html)